

***European Commission 6<sup>th</sup> Framework Programme***



***MICROCON***  
***A Micro Level Analysis of Violent  
Conflict***

***January 2007 – December 2011***

**Theresa Jennings**  
Project Manager

**HiCN's Second Annual Workshop**  
**Antwerp, 19-20 January 2007**



**H i C N Household in Conflict Network**

# ***The Consortium***

Institute of Development Studies, United Kingdom (Coordinator)  
University of the Andes, Colombia  
University of Rouen, France  
University of Cape Town, South Africa  
Centre for Economic and Social Research, Kyrgyzstan  
Centre for European Policy Studies, Belgium  
Centre for Research in Epidemiology of Disasters, KU Leuven, Belgium  
University of Ghent, Belgium  
DIW Berlin, Germany  
Institute of International Affairs, Italy  
Fafo AIS, Norway  
University of Alicante, Spain  
Institute for Intern. Coop. of German Education Association, Bulgaria  
Institute of Social Studies, The Netherlands  
Institute for Agricultural Economics, Romania  
Makerere University, Uganda  
Institute for Human Development, India  
University of Lisbon, Portugal  
University of Sussex, United Kingdom  
University of Oxford, United Kingdom  
UNU Institute for Environmental and Human Security, Germany  
Free University of Brussels, Belgium

## ***Main objective***

Create foundations for a new European research and policy agenda in the field of conflict analysis by developing innovative micro level, multidisciplinary approach to the analysis of the causes, impacts and long-term effects of violent mass conflicts.

## *Six specific goals*

- 1. Create and develop conceptual breakthroughs** in the understanding of micro level processes that lead to and result from violent mass conflicts, through the development of an integrated multidisciplinary framework

Achieved through the development of an integrated interdisciplinary framework, bringing together different perspectives on conflict analysis from a variety of disciplines into one coherent project.

MICROCON challenges the boundaries of these disciplines to build a new and exciting arena for conflict analysis.

## *Six specific goals*

- 2. Compile and collect qualitative and quantitative data** on violent conflict at the individual, household and group levels.

This will result in a new leading international reference database of qualitative and quantitative micro level facts and figures on violent conflicts across a broad spectrum, which will allow us to test the validity of our conceptual framework.

This database, located in Europe, will constitute an essential breakthrough in the state of the art of conflict analysis, enabling the development of urgently needed research on micro level conflict dimensions.

## *Six specific goals*

- 3. Advance and develop appropriate theoretical and empirical methods** for the analysis of violent mass conflict at the micro level

Including methods for the analysis of qualitative and quantitative conflict-related individual and group data and new models that combine and significantly extend cross-disciplinary perspectives on individual and group behaviour developed separately in different social sciences.

This will be undertaken with a view to develop a new research and policy agenda on the full cycle of violent mass conflicts, which places individuals and groups at the centre of their analysis.

## *Six specific goals*

- 4. Build and disseminate** constructive narratives on micro level conflict by linking micro-level processes to policy-relevant outcomes

For the use of European and international policymakers and practitioners, which will influence positively and usefully the design of effective and sustainable policy actions for the resolution, prevention and mediation of mass violent conflicts.

To support a new policy outlook on conflict prevention, mediation and resolution which focuses its attention not only on national and regional processes but on fundamental linkages between those policy processes and micro level interactions.

## ***Six specific goals***

- 5. Train and facilitate** the mobility of young researchers in Europe, as well as talented researchers in developing countries, in cutting edge theoretical and applied interdisciplinary methods for the analysis of micro level processes underlying violent conflicts

This will support the creation of a new generation of integrated interdisciplinary research in conflict analysis in Europe, through effective systems of transmission, sharing and learning of fundamental scientific knowledge.

## *Six specific goals*

- 6. Manage and support** a pan-European team of previously scattered researchers from various social science backgrounds to form a coherent project on a fundamental area of social science research and policy

Support critical partnerships between research and policy institutions in northern European countries and partners in new EU countries, other countries in southeastern Europe and in INCO target countries. This will promote the enhancement of research capacity and integration, across Europe and internationally, of researchers working on conflict-related issues and institutions located in conflict-affected regions.

# Programme Activities (PA) Interdependencies

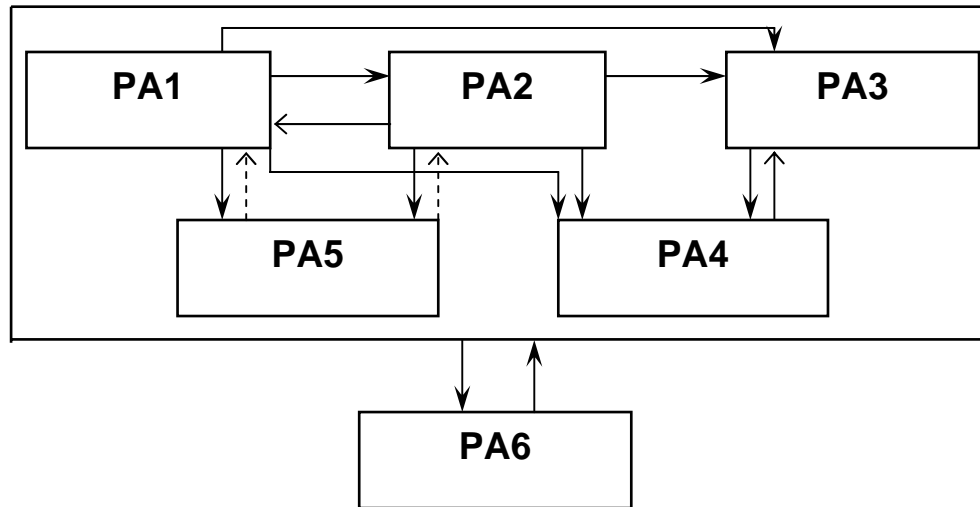

**PA1: Concepts and Measurement**

**PA2: Research and Knowledge**

**PA3: Policy Linkages and Synthesis**

**PA4: Dissemination and  
Communication**

**PA5: Training and Mobility**

**PA6: Management Strategy**

**Key:**

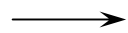

Direct effect

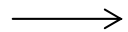

Immediate feedback effect

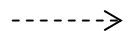

Long term feedback effect

# ***PA2: Research and Knowledge***

- **Group Formation, Identities and Mobilisation**

Objective: Further current understanding of (i) collective violence grounded in group identities and interactions and (ii) individual motivations for participation in collective acts of violence.

- **Contemporary Conflicts and Ethnic-Religious Tensions**

Objective: (i) Explore further particular aspects of group mobilisation in violent conflicts, namely the role of ethnicity and religion. (ii) Links sociological, economic and political aspects behind collective action, with the analysis of psychological categories of group identity and perception, and historical processes of religious and ethnic integration inside and outside Europe

# ***PA2: Research and Knowledge***

- **Gender Aspects of Violent Conflicts**

Objective: Analysis of gender aspects of violent conflicts, in particular the differentiation between male and female needs in conflict contexts, and between male and female perceptions of conflict.

- **Migration, Displacement and Refugees**

Objective: (i) Analyse displacement processes in regions of origin and causes of forced migration in conflict areas. (ii) Examine the societal position of refugees and migrants from conflict regions in the EU, in order to develop policy options for durable solutions.

- **Risk, Security and Coping Mechanisms**

Objective: Analysis of coping mechanisms developed by individuals and households to deal with risk forms of insecurity caused by violent mass conflicts.

# ***PA2: Research and Knowledge***

- **Poverty, Inequality and Social Exclusion**

Objective: Analysis of impact of violent conflicts on poverty, deprivation and social exclusion of individuals, households and groups, as well as the role of poverty and exclusion on social mobilisation and collective actions that may result in violent mass conflicts.

- **Violent Conflict and Health Outcomes**

Objective: Develop new methods to trace empirically the links between violent mass conflicts and health outcomes.

- **Governance and Institutions**

Objective: (i) Analysis of how institutions shape violent conflicts. (ii) Study management structures of violent mass conflicts at the local level. (iii) Link analytically local governance structures with national and international frameworks for conflict-management.

# Organisational Chart

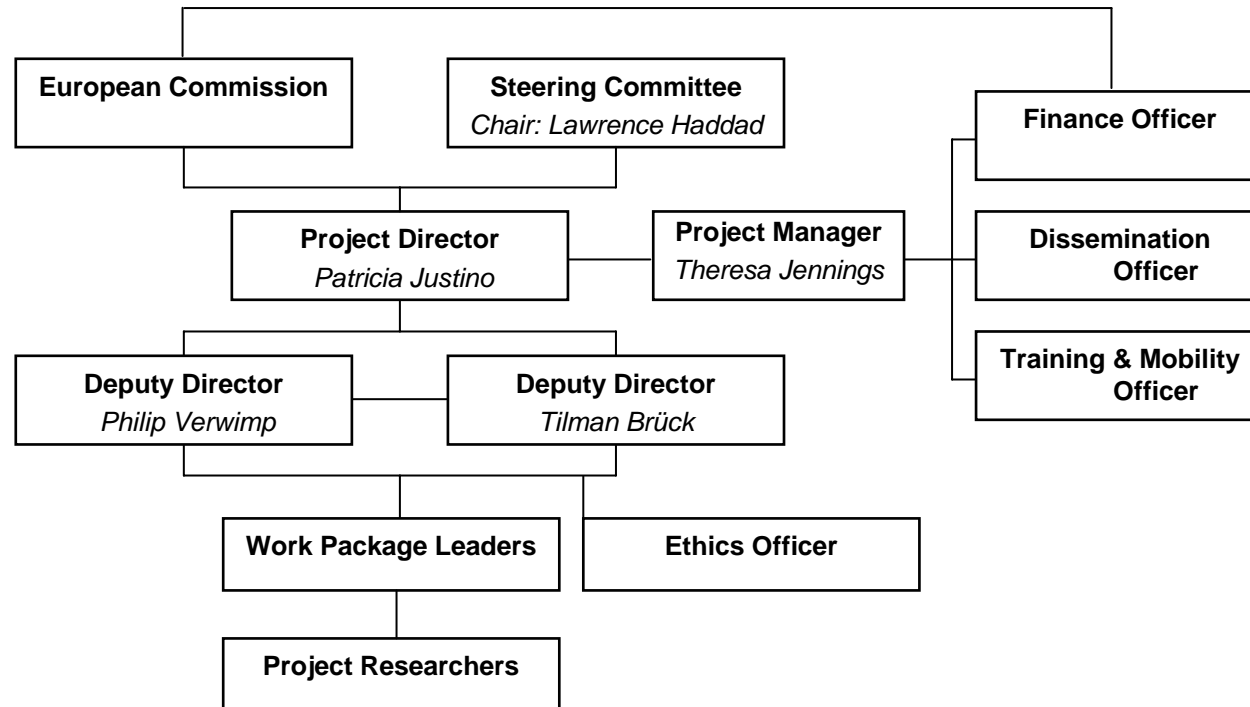

## Work Package Leaders:

Brück, Tilman  
 Castles, Stephen  
 Emerson, Michael  
 Guha-Sapir, Debarati  
 Harris, Colette  
 Justino, Patricia  
 Lianos, Michalis  
 Litchfield, Julie  
 Murshed, Mansoob  
 Pedersen, Jon  
 Stewart, Frances  
 Tocci, Nathalie  
 Verwimp, Philip  
 Vlassenroot, Koen